



Our range of display units, made of aluminium alloy and polypropylene, is constantly being enriched of new models in order to meet a wide variety of needs. They are meant for fruits and vegetables, but are also suitable for bread and other products. All the models we design and produce have a common feature: the utmost attention we pay to quality. High quality materials and high quality treatments provide high resistance to atmospheric agents, corrosion and pollution, thus allowing continuous external use.

“XP” LINE: a complete range of inclined, light and functional space-saving display units for fruits and vegetables. The use of wheels makes them very easy to move both inside the shop (for easy cleaning or to vary the presentation of food) and from outside to inside the shop (i.e. to store them at the end of the working day). When unused, the display units can be folded and stored to provide functional space-saving solutions.

“SHELF” LINE: a versatile range of display units, suitable for fruits and vegetables, but also for bread and different kinds of food. They can be used as single modules or to create island compositions, also for big spaces. Space-saving solutions can be provided.

“ARCH” LINE (patented model): a new concept of display unit, conceived to create multiple solutions of mobile island compositions. Thanks to the wheels and the arch, new combinations can be quickly created and all of them can be easily relocated for cleaning.

DISPLAY UNITS

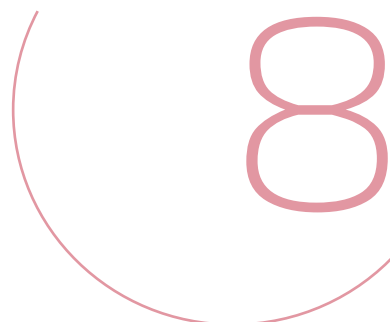

es



WHAT LIES BEHIND...

FRUITS AND VEGETABLES ELEGANTLY DISPLAYED, WITH GREAT HYGIENE AND COMFORT?

There is the experience of a company which has been working in this field for 40 years and has always used aluminium: a strong and versatile metal, unique in terms of longevity and strength.

There is the creativity of the owner who strongly believes that "robust" does not mean "heavy", that "hygiene" does not mean "cold"...and that high quality can be supplied at competitive prices.

There is the enthusiasm of an entire team, where every person is always ready to face new challenges with strong commitment and to cooperate as a team to achieve a common goal.

Last but not least, there is the strong support of our customers (important designers, small shops and supermarket chains), continuously rewarding us with their loyalty with long collaborations often lasting for decades.

Fruits and vegetables are displayed on professional units designed to look like true pieces of furniture. We are always proud to achieve with you our common goal.



LEGEND OF OPTIONAL FEATURES



European oak riser, warm and aesthetically pleasant



Hook system, to support crates at required height



Polypropylene staves, removable and washable in dishwasher. 2 colours available



Polypropylene perforated staves, removable and washable in dishwasher. 3 colours available



Articles available with coat of painting. RAL range of colours



DISPLAY UNITS FOR FRUITS AND VEGETABLES

XP LINE



JACK XP5

DISPLAY UNIT FOR 5 fruit-vegetable boxes*.
 The structure is made from anodised aluminium alloy and staves are made from polypropylene, with swivel wheels 125 mm diameter (2 with brake). Choose how many staves you need, they are also available in different widths. It is also available on request with bumper to protect the display from trolley collisions.

The picture shows a shelf with 17 staves (working shelf surface 152x45 cm)

RECLINING PART
 High: raised back (max)
 Low: lowered back (min)
 Short: removable back with minimum expansion
 Long: removable back with maximum expansion

* We refer to 30 cm deep boxes

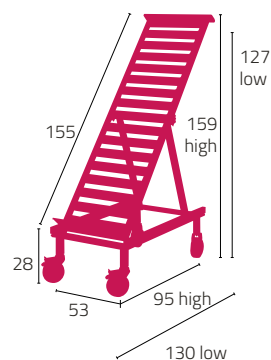

JACK XP10

DISPLAY UNIT FOR 10 fruit-vegetable boxes*.
 The structure is made from anodised aluminium alloy and staves are made from polypropylene, with swivel wheels 125 mm diameter (2 with brake). Choose how many staves you need, they are also available in different widths. It is also available on request with bumper to protect the display from trolley collisions.

The picture shows a double shelf with 17 staves (working shelf surface 152x98 cm)

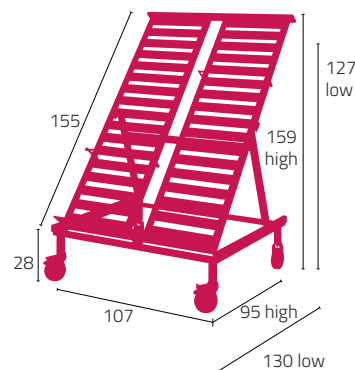

QUEEN XPE6

DISPLAY UNIT FOR 5+1 fruit-vegetable boxes*. The structure is made from anodised aluminium alloy and staves are made from polypropylene. Removable front box carrier, swivel wheels 125 mm diameter (2 with brake). Choose how many staves you need, they are also available in different widths. The lower removable box carrier is also available on request with bumper to protect the display from trolley collisions.

The picture shows a shelf with 17 staves (working shelf surface 152x45 cm + removable box holder 44x50 cm)

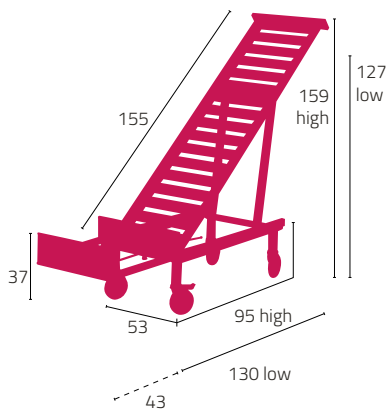

RECLINING PART
 High: raised back (max)
 Low: lowered back (min)
 Short: removable back with minimum expansion
 Long: removable back with maximum expansion

* We refer to 30 cm deep boxes

QUEEN XPE12

DISPLAY UNIT FOR 10+2 fruit-vegetable boxes*. The structure is made from anodised aluminium alloy and staves are made from polypropylene. Removable front box carrier, swivel wheels 125 mm diameter (2 with brake). Choose how many staves you need, they are also available in different widths. The lower removable box carrier is also available on request with bumper to protect the display from trolley collisions.

The picture shows a double shelf with 17 staves (working shelf surface 152x98 cm + removable box holder 44x105 cm)

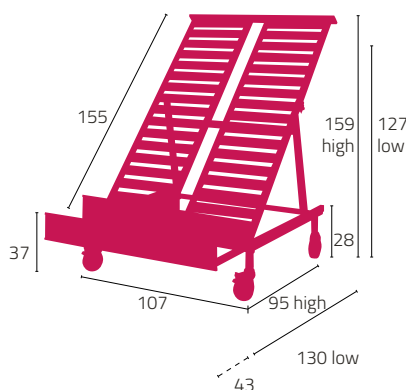

"SHELF" LINE



open



folded to reduce overall dimensions



extended specular elements



specular elements to reduce overall dimensions

POKER

This display unit can be used in four different ways and it is characterised by four main features: versatility, practicality, robustness and aesthetics. Thanks to the high quality aluminium alloy structure and to the anodic treatment, this display unit can be used outdoor without suffering from bad weather conditions.

On request it is supplied with a rubber bumper to protect the display unit from trolley collisions, which should be fixed directly on the unit.

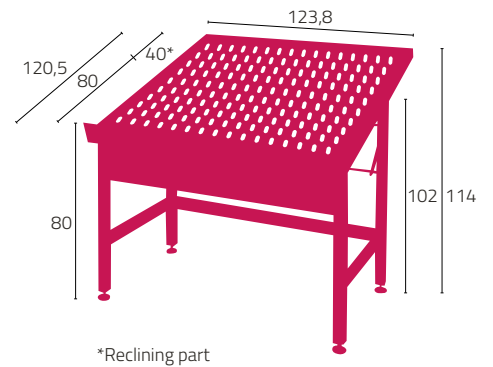

Easy and versatile, for four different solutions

"SHELF" LINE

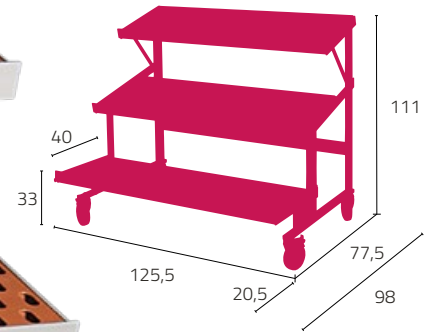

FULL

The FULL model, available in three levels, is made of primary aluminium with top-quality anodising and polypropylene staves. It is solid, easy to clean and long-lasting. It can be used both inside and outside the store, thanks to the folding lower shelf that, together with the non-marking and anti-noise rubber wheels, makes it very easy to go through the doors.

QUADS POLY

This slanted-level display unit can be supplied to measure and the number of shelves can be chosen by the customer. The whole length can be divided into multiple units to optimize the quantity of uprights and, consequently, the price. Made in anodised aluminium alloy and polypropylene staves, these display units can be either leaned against the wall or against one another in the middle of the room to create bi-frontal compositions accessible on both sides.

In the picture a 3-level example (measures of each shelf: 120x60 cm)

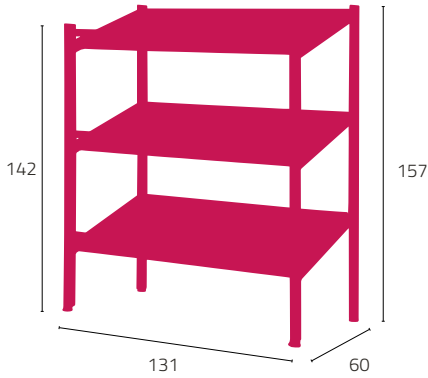

In the picture a 3-level example (measures of each shelf: 120x60 cm) equipped with a horizontal upper shelf measuring 120x40 cm.



Examples of composition

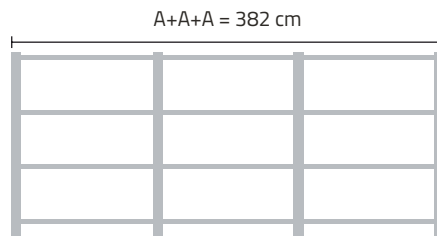
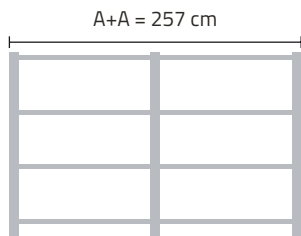
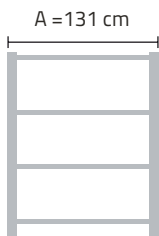

"ARCH" LINE

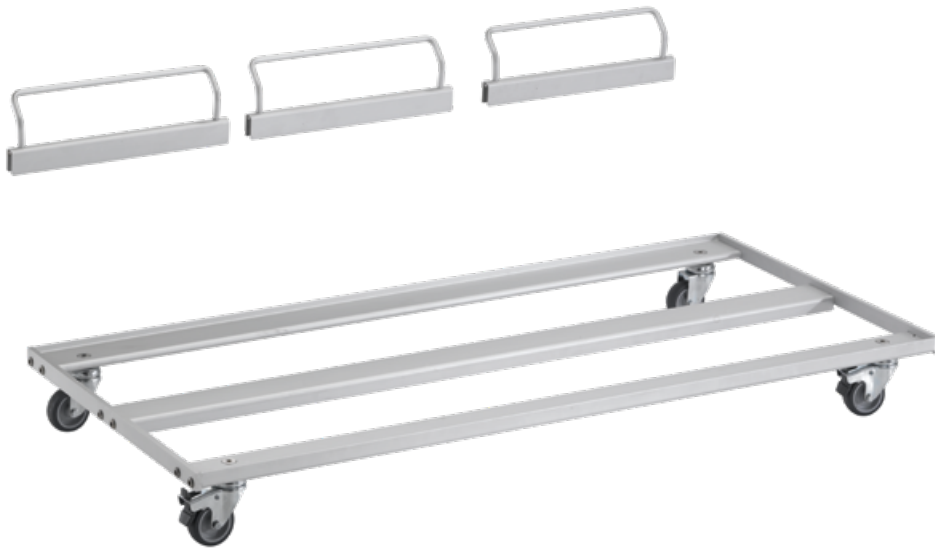

FAST 1 58x37x11,5 cm

FAST 2 78,5x57x11,5 cm

FAST 3 118x57x11,5 cm

FAST

PATENTED MODEL

Our Fast model is composed of 2 main elements: a wheeled box base (all wheels are provided with brakes) and a snap-fit device which can be inserted on both edges of Euro Boxes to incline upper crates towards the user. These 2 elements are synergically combined to create "mobile" island units of superposed crates. A new patent pending system, simple and innovative at the same time, to display fruits and vegetables in a functional and hygienic way.

SOME PERSONALIZATION EXAMPLES

in cooperation with our dealers

